

PLUS OZONE™ INJECTOR KIT

CONNECTION AND ADJUSTMENT PROCEDURE

Read all instructions prior to performing work. If you do not understand these instructions or are unable to perform the work, contact your system provider for assistance

8000 systems equipped with a factory installed Plus Ozone™ come with a visible green logo on the cabinet access door and the Plus Ozone™ generator installed into the upper cabinet. Reference Dia. #1

SAVE THESE INSTRUCTIONS

Kit includes:

- 1ea. Ozone Injector Manifold
- 1ea. Ozone Check Valve Kit

Tools and supplies needed:

- *Timer with second hand
- *16oz water bottle

*Only needed for type #2 setup

NOTICE! If you choose to disconnect the Plus Ozone™ purification system, or need to electrically disarm it for any reason, follow the “Disable Plus Ozone™ Option” provided in this instruction

ELECTRICAL CONNECTION

The Plus Ozone™ generator comes pre-wired to the 8000 control system as shown in Dia #1, there are no additional electrical connections required

Dia. #1

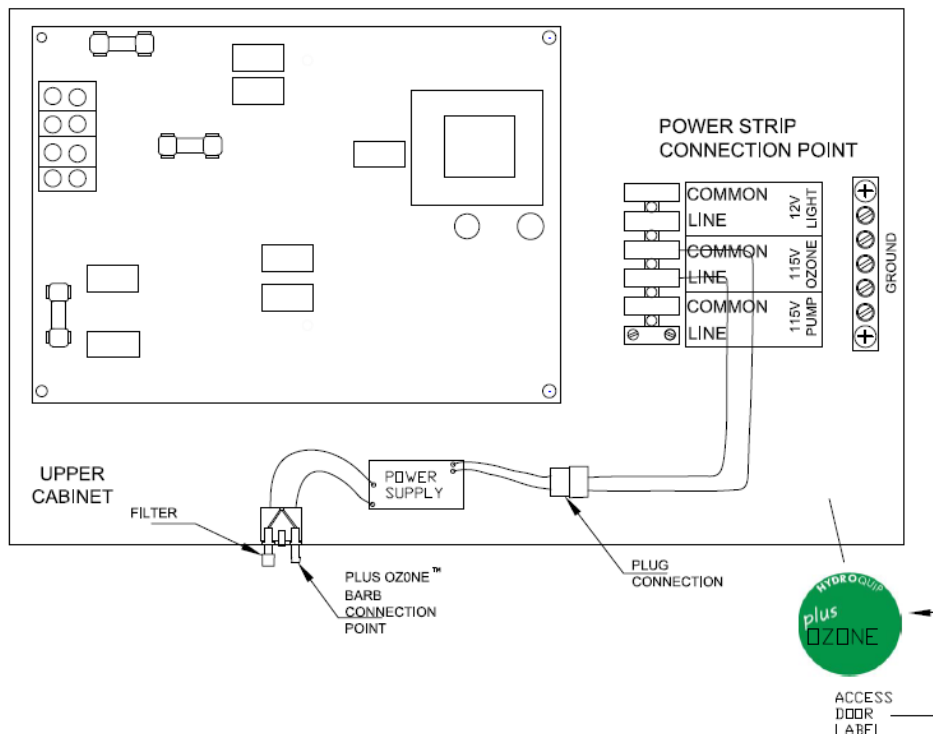

LOCATING THE OZONE INJECTOR MANIFOLD

1. The manifold must be placed at or near the operating equipment
2. Place the Ozone Injector Manifold into the return system plumbing as the last item in the equipment sequence before the water returns to the jets or wall fitting. Reference diagram #2 for typical plumbing layout, correct manifold location and water flow direction.

Note that your system provider may have different arrangement for pump filter and heater sequence, however this manifold must be placed after the water has passed through all equipment

WARNING! Placing this manifold in any other location i.e. in between the filter pump or in front of the heater will cause operational problems and equipment damage including loss of pump prime, reduced filtration, and heater damage that is not covered under warranty.

3. The manifold must be plumbed in the correct direction for water flow. The arrow label placed on the manifold shows the direction water must flow through the manifold for proper operation. (Label arrow should not be pointing toward any other component in the plumbing system)
4. Connect manifold to system pipe with PVC glue. **DO NOT** mount manifold upside down or vertically

INSTALLING CHECK VALVE KIT WITH TUBING

Follow instructions included with the Ozone Check Valve Kit to connect supply tubing between the Ozone Injector Manifold and cabinet mounted Plus Ozone™ generator barb.

Some extended length injector manifolds (not shown) come with a bracket and bolt assembly to help support the additional plumbing weight. When provided, install bracket and secure to the plastic base with screws as shown in Dia.# 3

Dia #3

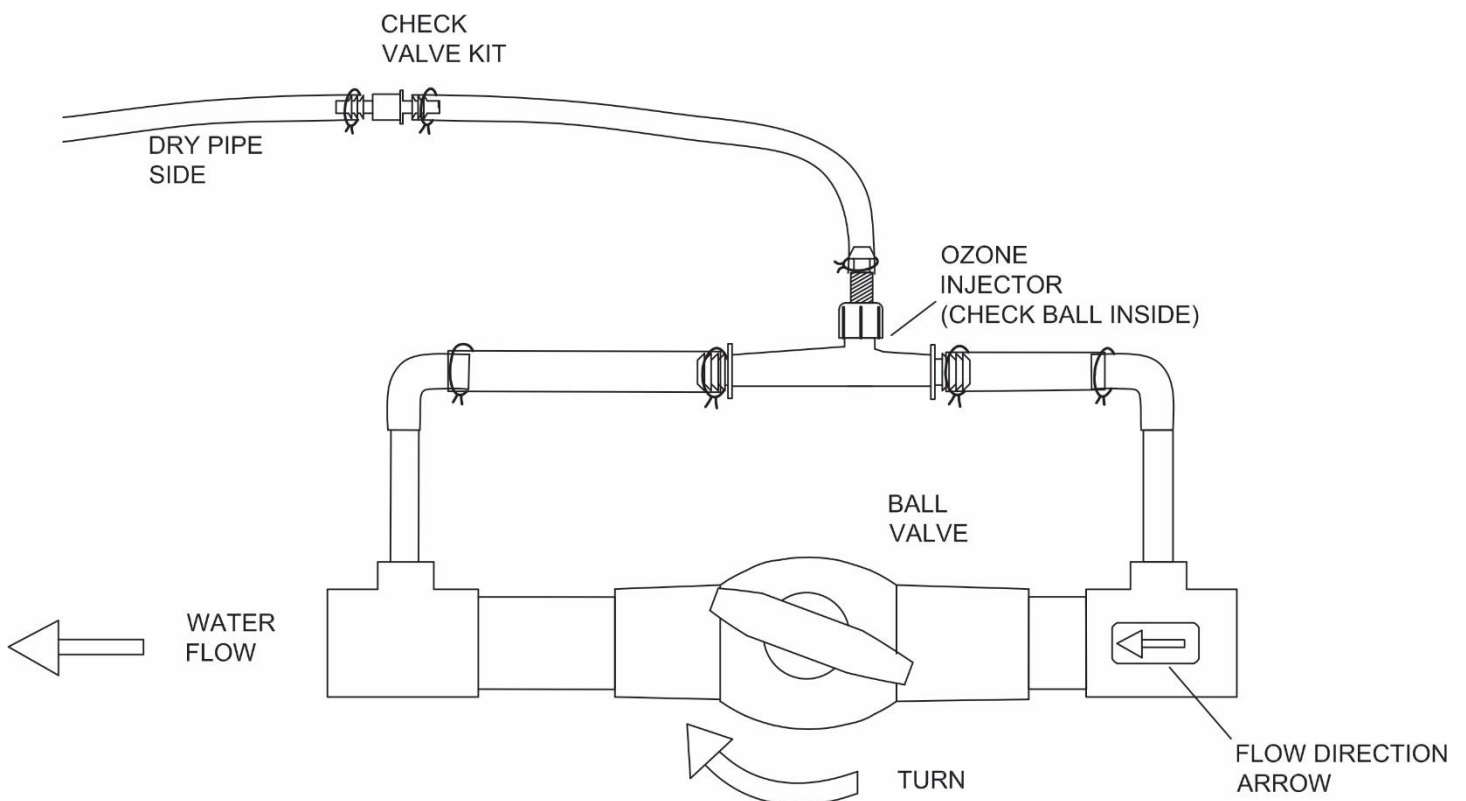

Dia. # 2

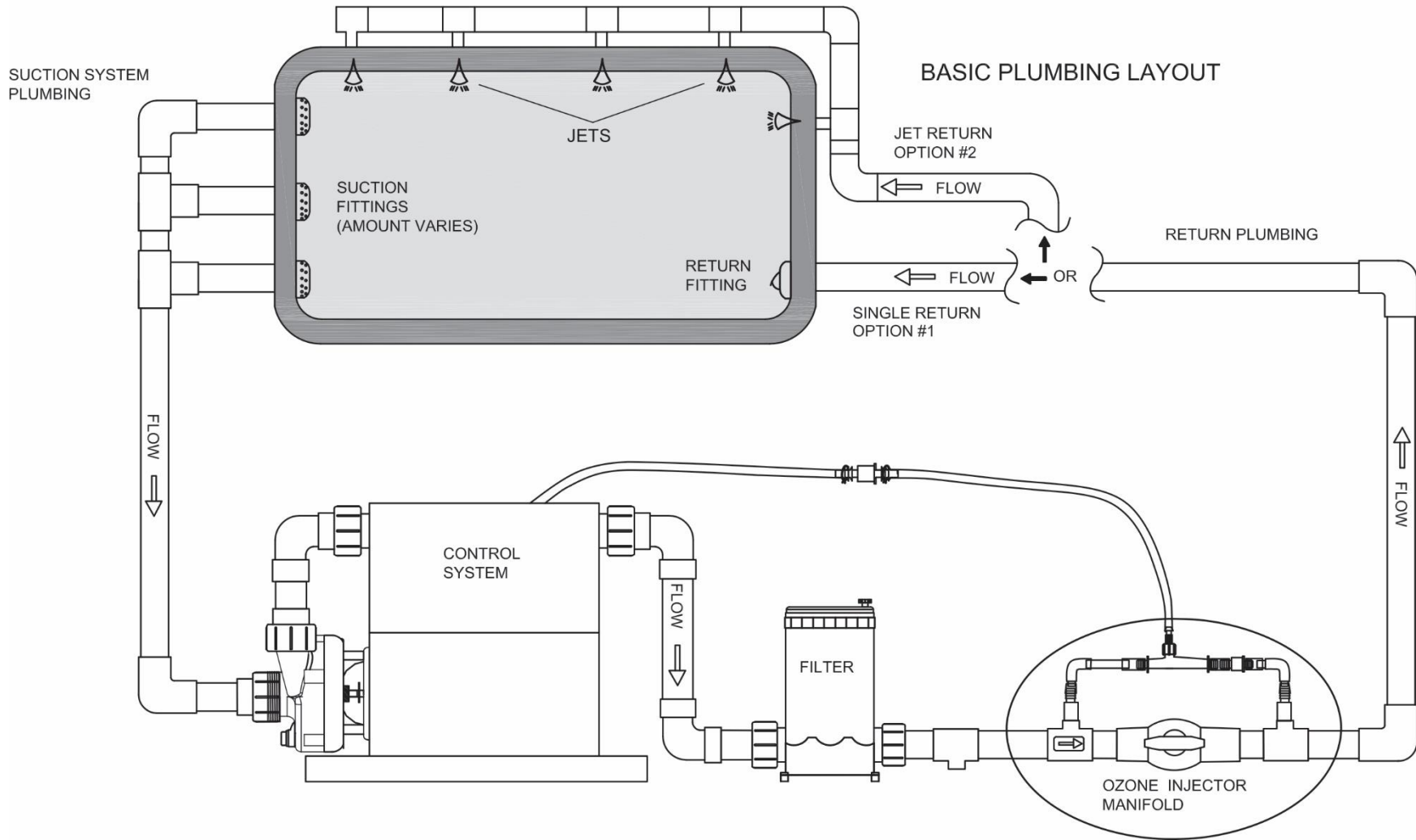

ADJUSTING OZONE VACUUM FLOW

Follow these steps to fine tune your ozone delivery and maximize the sanitation benefit from your Plus Ozone™ system. The ozone injector can only be adjusted when the vessel/tub is full of water and the pump is operating. Select your pump and return plumbing type (#1 or #2) then follow procedures for proper adjustment

PUMP AND RETURN PLUMBING TYPE #1
1-SPEED LOW FLOW CIRCULATION PUMP WITH SINGLE
RETURN INLET FITTING (NO JETS)

1. Confirm the Check Valve Kit is installed properly
2. When the pump is operating, slightly turn the ball valve to divert water through the ozone injector DIA #3

View the water return fitting Dia #4 and adjust the valve handle until very small ozone bubbles are detected coming from the return fitting

TYPE #1 TIPS

A properly adjusted valve allows only small bubbles to project 4-5 feet from the fitting and swirl around for a few seconds before rising to the surface.

Larger bubbles that project less than 2 feet from the return fitting and quickly rise to the surface are less effective for water treatment, produce unwanted noise, and deliver an undesirable ozone gas smell. Continue to adjust the valve until a small bubble size is visible

*When filters become dirty, the water velocity slows and ball valve adjustment may become necessary again to obtain the smaller bubble size

Dia.# 4

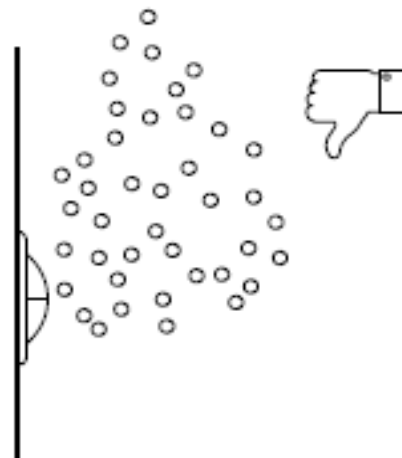
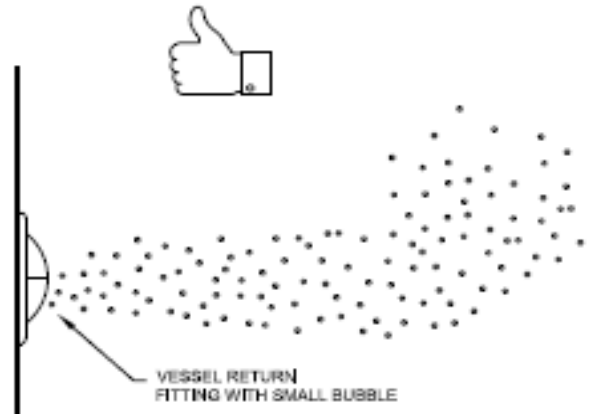

PUMP AND RETURN PLUMBING TYPE #2

1-SPEED OR 2-SPEED HIGH FLOW PUMP WITH MULTIPLE RETURN INLETS (JETS)

1. Adjustment must be made when pump is operating and water is flowing (Motors with 2-speeds must be placed in low speed) slightly turn the ball valve to divert water through the ozone injector Dia #3
2. Disconnect ozone tubing from generator barb and place tube end in 16oz. bottle filled with water (Dia #5) Time how long it takes the ozone injector to empty the water (100% vacuumed out) Re-test and adjust ball valve until it takes between 50 and 70 seconds to empty the water bottle.
3. When adjustment is finished, remove 100% of the water from the hose and reconnect to the Plus Ozone™ barb.

TYPE #2 TIPS

A properly adjusted valve allows approx. 0.5 Standard Cubic Foot and Hour (SCFH) of ozone gas to be delivered (vacuumed) from the generator. The water bottle technique is an easy measurement method and excellent substitution for SCFH measuring equipment

TROUBLE SHOOTING

Ozone is not being delivered through vacuum line when pump is on

Symptom

- Injector assembly plumbed backward-
- Ball Valve not adjusted correctly-
- Kinked or flat tubing-
- Check valve placed in wrong direction
- Check valve stuck
- Check ball in ozone injector stuck-

Cure

- Correct assembly direction using instructions**
- Reference the adjustment instructions**
- inspect and cure**
- Review kit install instructions**
- Contact system supplier**
- Unscrew cap and confirm check ball moves free (Dia. #3)**

*Note that over time the filter will become dirty and ozone delivery may slow or stop due to reduced water flow. Clean the filter first before attempting to re-adjust ball valve for improved vacuum

Ozone smell is strong

Symptom

- Ball Valve not set correctly

Cure

- Adjust Ball Valve per instructions**

MAINTENANCE

Periodic checks to tubing, check valve, and proper valve adjustment

Dia. #5

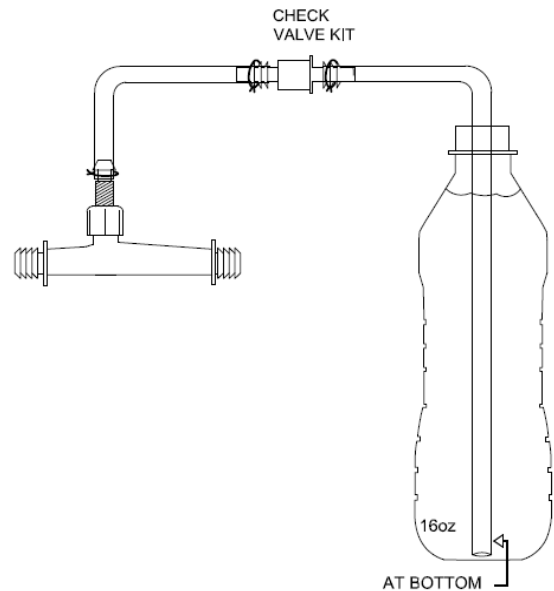

ABOUT PLUS OZONE OPTION

IMPORTANT! Plus Ozone™ generators operate at high voltage and must never come in contact with water at any time. The ozone tubing kit includes a one-way check valve that must be installed correctly to prevent the backflow of water into the ozone generator. Failure to install the valve or installing the valve backwards may cause permanent damage and will void the product warranty.

WARNING! Ozonators exposed to water may cause system electrical problems and potential harm to the user. **DO NOT** connect tubing to the ozone generator barb, unless the check valve has been installed correctly per the instructions

DISABLE PLUS OZONE™ OPTION:

If you are unsure how to connect plumbing, or if you choose not to use the Plus Ozone™ it's important to disconnect the electrical power. To disconnect power, simply disconnect the male and female plug connection point as shown in Dia #1, then coil and store plugs out of the way in the cabinet.

OPERATION:

The Plus Ozone™ system is only activated when the main filter pump (pump #1) is operating in a filter cycle. Reference “Filtration Settings” in your operation manual to adjust filter cycle duration, that will directly affect the length of time the Plus Ozone™ operates each day.

ABOUT:

Plus Ozone™ is a Corona Discharge (CD) ozone generator that is self- operating, self-regulating and contains no serviceable parts. **DO NOT** attempt to alter, adjust or repair this device. The Plus Ozone™ generator is automatically activated by system programing, to insure it does not operate without the pump.

It is normal to encounter a purification smell at the water surface confirming ozone is being generated and delivered. Potency has been regulated on this device, and remains non-adjustable for your safety and convenience. Ozone gas applies an instant sanitation effect to the water, however, is does not build or maintain a lasting residual. Therefore, ozone becomes ineffective shortly after the generator is turned off.

Ozone generated by this device is solely intended for the sanitation of water and the inner walls of the delivery piping system by means of direct exposure, the effectiveness and expected benefit is strictly limited to the time during operation.

IMPORTANT! Consult with your tub manufacturer and/or local pool and spa professional to establish an additional chemical regiment for water care.

SERVICE:

1. The Plus Ozone™ barb has a removable intake filter that must be cleaned annually. Remove the filter (ref filter on Dia #1) and wash with clean water, allow to dry and re-install.
2. The one way check valve should be visually inspected annually to confirm water is not getting back to the Plus Ozone™ generator.

WARNING! Disconnect tubing from the generator and electrical connection as described in “Disable Plus Ozone™ option” immediately if found to have water present in tubing between the check valve and ozonator. Contact your system supplier for replacement valve and tubing.

3. Plus Ozone™ CD generators have a rated life cycle of 9000 hours, after which the output of the generator is greatly diminished and requires replacement. Calculate your annual operational hours by multiplying your accumulated daily filter cycle time by 365. This will give you an idea when the generator will need replacement. Contact your system provider for instructions for replacement.



HYDROQUIPTM

510A N. Sheridan Street · Corona, CA 92880-2024

Email: info@hydroquip.com · Internet: <http://www.hydroquip.com/>

Telephone: 951.273.7575 · Fax: 800.332.7190